



Close loop Stepper motor driver

SEB2M55



Features

- High performance, low noise, high speed and torque, excellent stability
- Single / dual pulse input
- 16 selections of uniform angle and constant torque subdivisions, the max resolution up to 51200 steps/rev
- Adoption of 4-wires-control circuit greatly reduces noise and increases the rotation stability
- The max response frequency up to 200KHz
- Once the pulse stops for more than 100ms, the coil current will be halved automatically, to prevent the overheating
- Bipolar constant current chopper control improves the output speed and power of the motor
- Photoelectric-isolated signal input / output
- Current range: 0.1A ~ 5A
- Single power input, voltage range: DC24 ~ 50V (The optimal voltage is DC48V)
- Signal source voltage: DC3.3 ~ 28V (Arbitrary input without additional current limiting resistor)
- Working mode: Pulse mode, I/O mode
- Error protection: ①Low supply voltage ②High supply voltage ③Phase open Circuit ④Phase overheating ⑤Encoder out of tolerance
- Size: 117×75.7×40.6 (mm) , Net weight: 0.29kg

Description

The SEB2M55 is equipped with a 32-bit ARM Cortex-M4 core high-performance microcontroller, which can effectively improve the overall efficiency of the operation speed up to 200MHz in combination with the advanced manufacturing process. The maximum speed can reach more than 3000 rpm, and the high-speed torque attenuation is far lower than that of the ordinary open-loop stepping driver. It can greatly improve the high-speed performance and torque utilization of the closed-loop stepping motor, effectively reduce the vibration and heating of the closed-loop stepping motor, and thus improve the processing efficiency and precision of the equipment, The input voltage of the driver is DC24V ~ 50V (The optimal input voltage is DC48V). The driver is powered by a single power supply. Adapt to a 2-phase hybrid closed-loop stepping motor with an outer diameter of 56mm ~ 60mm and a phase current below 5A. The load based current control technology is adopted inside the driver, which can effectively extend the service life of the closed-loop stepping motor and reduce the heating. The driver has built-in position arrival signal and alarm signal output, which is convenient for the controller to monitor and control.

Applications

Woodworking engraving machine, laser engraving machine, marking machine, labeling machine, die bonding machine, wire bonding machine, UV printer, 3D printer, inkjet printer, plotter, embroidery machine, glue dispenser, glue filling machine, soldering machine, BGA rework station, laminating machine, placement machine, heat press machine, backlight laminating machine, coating machine, reciprocating machine, terminal machine, wire stripping machine, wire winding machine, solder paste printing machine, PCB drilling machine, V -CUT machine, target machine, FPC reinforcement machine, coating machine, lamination machine, IC sorting machine, IC burning machine, tape machine, medical equipment, non-standard equipment XYZ measuring instrument, connector assembly machine, SMT peripheral equipment, etc.

Microstep Setting List

Pulse/rev	400	800	1000	1600	2000	3200	4000	5000	6400	8000	10000	12800	20000	25600	40000	52100
D1	ON	OFF	ON	ON	OFF	OFF	ON	OFF	ON	ON	OFF	OFF	ON	OFF	OFF	OFF
D2	ON	ON	ON	OFF	ON	OFF	OFF	OFF	ON	ON	ON	ON	OFF	ON	OFF	OFF
D3	ON	ON	ON	ON	ON	ON	ON	ON	OFF	OFF	OFF	OFF	OFF	ON	OFF	OFF
D4	ON	ON	OFF	ON	OFF	ON	OFF	OFF	ON	OFF	OFF	ON	OFF	OFF	OFF	ON
D5	OFF: Forward rotation, ON: Reverse rotation															
D6	OFF: Internal enable, ON: External enable															
D7	OFF: Faulty output, ON: Disconnect output															
D8	Null															
D9	OFF: PU + DR															
	ON: CW / CCW															
D10	OFF: External pulse, ON: Internal pulse															

SEB2M55

Dimensions

Side installation drawing

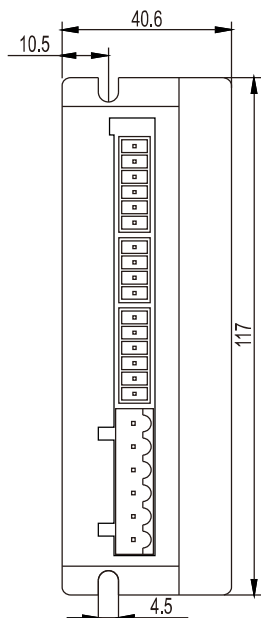

Front installation drawing

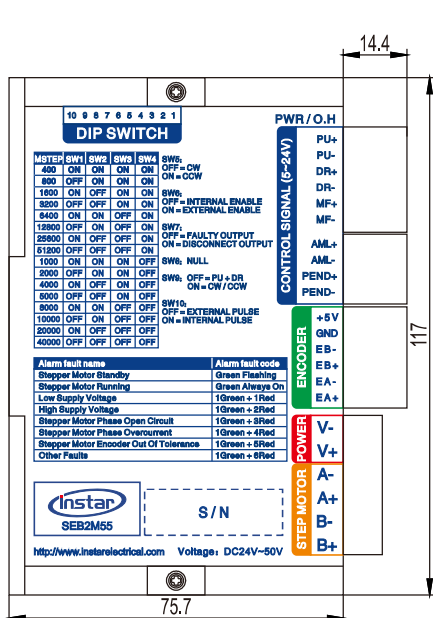

Wiring diagram

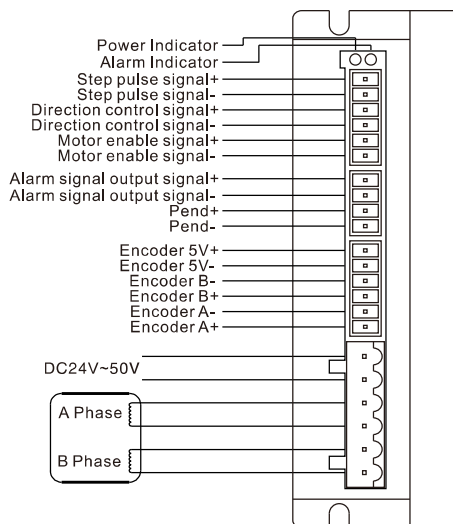

Pin Function Description

Mark	Function	Instruction
POWER	Power indicator	When the power is on, the indicator light flashes; When receiving pulse signal, the indicator light is always on.
O.H	Fault indicator	The red indicator lamp flashes when the power supply voltage of the closed-loop stepping driver is low, the power supply voltage is high, the phase is open, the phase is overcurrent, and the encoder is in fault.
PU+	Input signal positive side	Connects +3.3V ~ +28V pulse signal power.
PU-	Pulse signal	When the falling edge is valid, the closed loop stepper motor moves a step as the pulse become lower, input resistance is 220Ω. Requires: low level +0V ~ +0.5V, high level +4V ~ +5V, pulse width >2.5 μs.
DR+	Input signal positive side	Connects +3.3V ~ +28V pulse signal power.
DR-	Direction control signal	For changing the direction, input resistance is 220 Ω. Requires: low level +0V ~ +0.5V, high level +4V ~ +5V, pulse width >2.5 μs
MF+	Input signal positive side	Connects +3.3V ~ +28V pulse signal power.
MF-	Motor free signal	When the low electrical level is valid, it cuts off the closed loop stepper motor current, the driver stops working and closed loop stepper motor will be in a free state.
ALM+	Alarm signal output positive side	When the low supply voltage, high supply voltage, phase open circuit, phase overheating and encoder fault alarm, the alarm signal is effective (the output optocoupler is on).
ALM-	Alarm signal output negative side	ALM+ is connected with the pull-up resistor to the positive pole of the output power supply, and ALM- is connected with the negative pole of the output power supply. The maximum driving current is 10mA.
Pend+	Position reaches the positive end of signal output	When the driver has completed the given pulse, the position arrival signal is valid (the output optocoupler is on).
Pend-	Position reaches the negative end of signal output	Pend+ is connected with the pull-up resistor to the positive pole of the output power supply, and Pend- is connected with the negative pole of the output power supply. The maximum driving current is 10mA.
+V	Power+	DC24 ~ 50V (The optimal voltage is DC48V)
-V	Power-	
+A, -A	Connect to the closed loop stepper motor	Please refer to the closed loop stepper motor connections.
+B, -B		